

Lock and Keyhole Plate #065

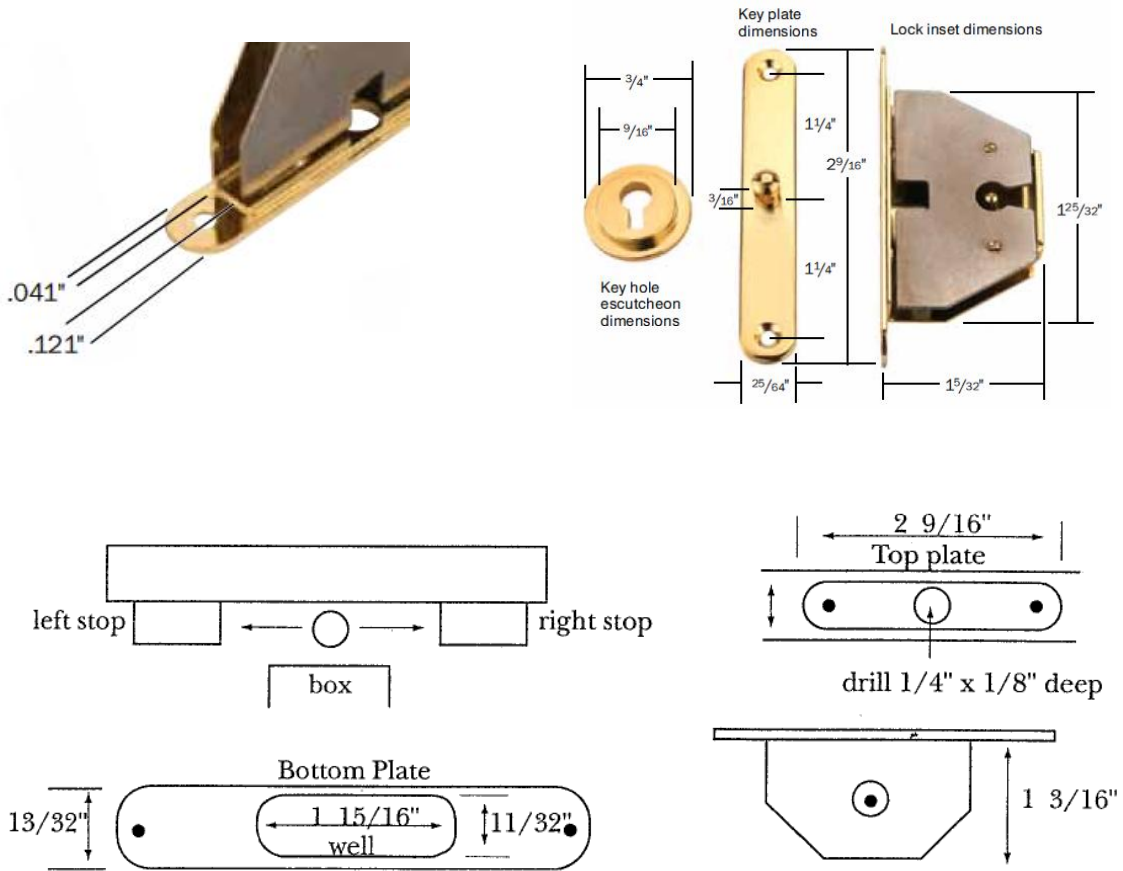

Tools Needed

Inverted router table or hand router with 11mm router bit ($13/32''$) and $11/32''$ upscale HSS router bit.

Some Notes:

This lock is a full mortise design and is more difficult to install than a 1/2 mortise. The difference in width between the top plate and the lock itself is very small ($1/8''$) so it is important to have the correct sizes of router bits and have the correct stops set on your router table.

Hinges must be installed and top and bottom walls of the box lined up perfectly before installation is made. Any change in hinge dimension will throw off the lock dimensions.

Installation Instructions

1. Make the top and bottom plate cuts first and only 0.060" (1/16") deep so that the top plate rests flush with the top of the box lid. Use a test piece of wood to determine where the fence settings and stops go. The thickness of your box walls will determine the back fence settings and the length of your box will determine the left and right stop settings. *Note: Distances between the left and right stops should be the same from the middle of the router bit. On top lid plate rout you will have to drill a 1/4" hole in the center of the cut to allow for the lock knob.*
2. Rout or drill depth of well using a 11/32" router bit on a mortise drill. Rout only to depth of 1-13/16" and no deeper so that lock rests of bottom of well. This is important as the lock hangs from the top plate and is attached with two small rivets and brazing solder. The top knob must line up perfectly with the bottom lock hole on the lock plate. Otherwise it will hit the lock plate and eventually loosen it from the lock, especially if the well is too deep and does not give it support. If the knob rubs against the lock hole, you may grind this hole to a slight larger diameter with a Dremel Moto Tool using a variable speed on low speed with a diamond grinding stone of 1/8" diameter. This will widen the hole nicely and a hand reamer can be used to clean the edges. Be sure to blow brass dust off the lock plate and not wipe it off. The brass dust is very abrasive and will scratch the epoxy surface of the lock plate if you wipe it off.
3. Key hole installation. A jig must be made for the keyhole marking in order to line up perfectly the keyhole with locking mechanism pin. (See sketch for details of this jig.)

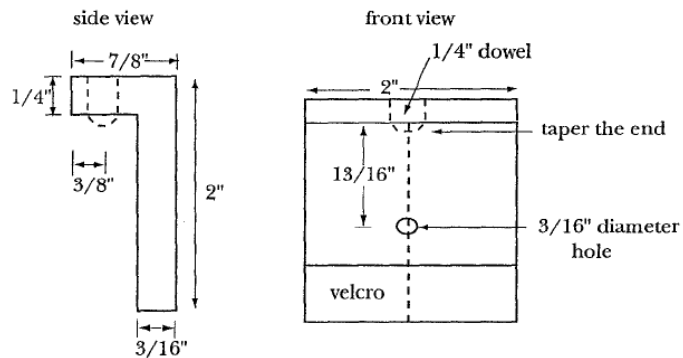

4. Drill a 9/16" hole for large plate and 1/2" hole for the small plate. Use a wooden shim stock to support well while drilling. Do not drill into well without this shim stock or you may crack the box around the well. Install large keyhole with 5 minute Devcon Epoxy by applying a small bead around the inside of the rim.
5. Center the keyhole plate over hole and press into hole. Clean up excess epoxy with denatured alcohol and Kleenex tissue. Keep tissue clean and continuously have a moistened piece on hand to clean with around hole while pressing keyhole plate into position. To hold in place while drying, use masking tape to tape over lower 1/2" of keyhole plate while keeping plate centered on lock pin. Then use a 6" Pony Spring clamp with vinyl covers to clamp the keyhole plate. Make sure these clamps have a rubber/vinyl cover to prevent marring the brass. Allow 15-30 minutes to dry and remove clamp and tape and clean up around keyhole with alcohol dampened tissue. Rub clean around plate with felt block.

Note: Occasionally the rout for the top plate will be too deep- use double stick foam tape under the top and bottom plates as necessary to raise the plates flush with the box rims. Both of the top and bottom plates need to be flush with the outer rim in order for lock to work smoothly. Also, occasionally the keyhole plate will not line up perfectly with the lock pin mechanism. This can be corrected by using a burr grinder on a Daniel Moto Tool to slightly grind off one side of the inner hole to compensate for the centering of the plate.